

REVISION DATES				MECHANICAL DEPARTMENT		RR	SERIES	CLASS
3-30-78						WM	25001-25155	B-112 A
5-6-80								
5-16-84								
				HUNTINGTON, W. VA.		9-25-75		B-38

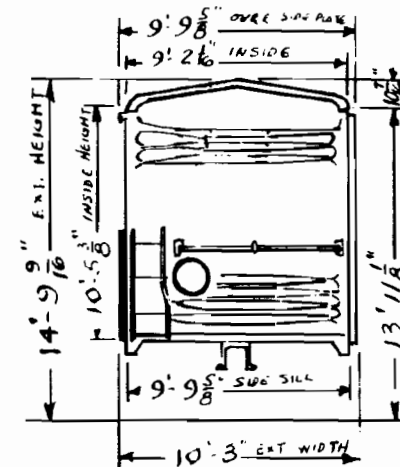
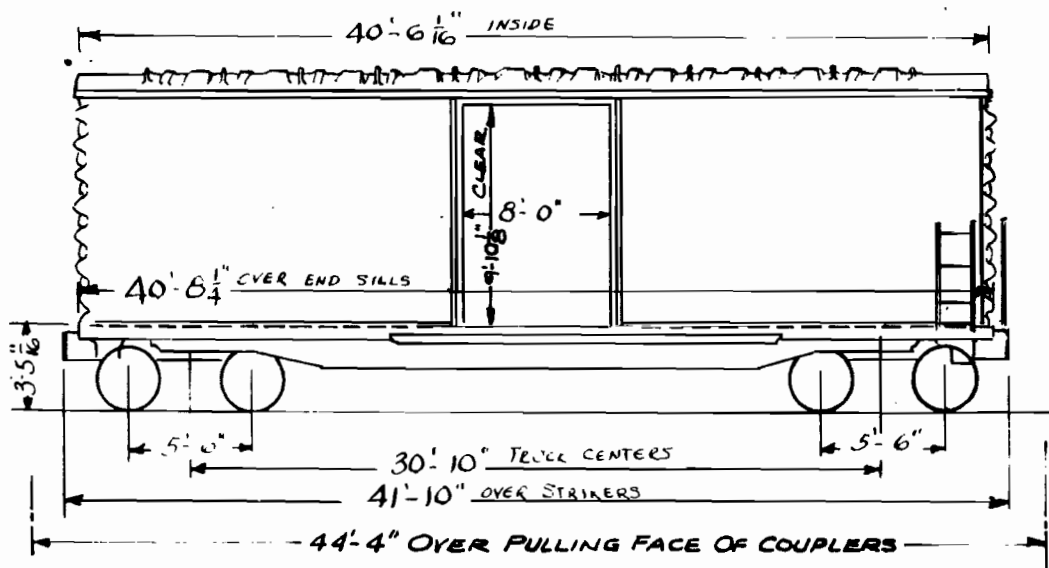

GENERAL DATA	CAR BODY DATA	TRUCK DATA	MISCELLANEOUS
BUILT BY - A.C.S.F.	BRAKES - AB 7 1/2" BUSHED CYL. CONVENTIONAL	TYPE -	NOTE: 1
YEAR BUILT - 1953 NOTE: 1 AND 2	BRAKE ARRANGEMENT -	GENERAL DWG -	* ORIGINAL CARS 4201-4450, 25001-25110
CUBIC CAPY. - 5060	CENTER SILL - 36.2 LB. ZEE SECTION	JOURNAL - 5 1/2 X 10 FRICTION	REBUILT NOV-DEC. 1970 AND 25111-25155
AVERAGE LD. LMT - 128,200	COUPLER - TYPE "E" 6 1/4" X 8"	SPRING TRAVEL - 2 1/2"	REBUILT OCT. 1971 TO FEB. 1972 IN COMPANY SHOP.
AVERAGE LT. WT. - 48,800	DRAFT GEAR - M901	WHEELS - 33" DIA. 1W.W.S.	NOTE: 2
BUILDERS REFERENCE - ORDER NO. 01-3959	DOOR - SINGLE SLIDING - YOUNGSTOWN	WEIGHT ONE TRUCK -	CARS 25069, 25079 AND 25136
RAILROAD SPEC. -	DOOR ARRANGEMENT - B-112	BRAKE SHOES - 2" COMPOSITION	ARE EQUIPPED WITH ADJ. LOADERS.
GENERAL ARRANGEMENT DWG. -	END - STEEL 3/16" TOP AND 1/4" BOTTOM		
CLEARANCE - PLATE "B"	FLOOR - 2 1/4" LAMINATED HARDWOOD		
CURVATURE - UNCOUPLED -	HAND BRAKE -		
COUPLED TO BASE CAR -	LINING -		
CENTER OF GRAVITY - LIGHT -	UNDERFRAME - RIGID		
LOADED -			* NOT A.A.R. REBUILD