

Built 1935-1959, Company's Shop

SAND CARS X-1201 to X-1212 (1954)
 SAND CARS X-1213 to X-1215 (1959)
 BALLAST CARS 1575-1598 (1959)
 GRIT CARS - JUNE, 1959

Covered Hopper Cars No. 500-5059
 Class LO

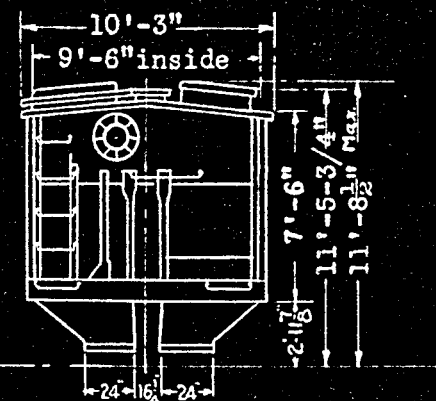
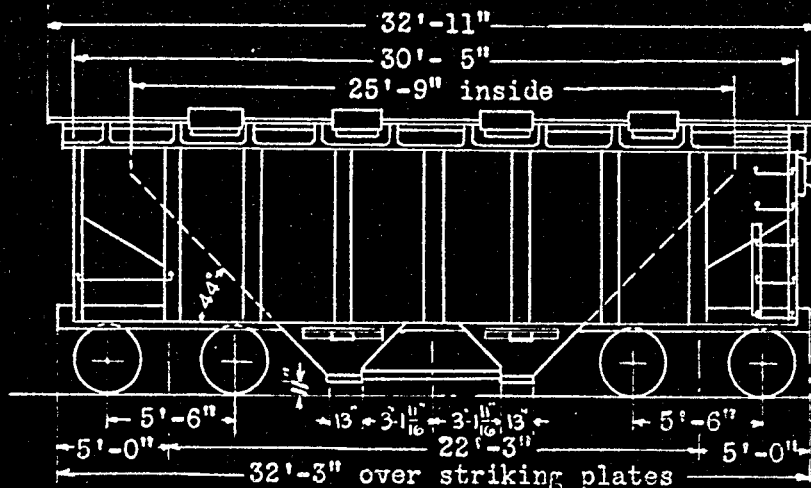

Sand Cars No. X-1201 to X-1215
 Grit Cars No. 5037, 5051, 5052, 5053, 5048

GENERAL		DRAFT (Continued)	
1. Capacity - level 1425 cu.ft.	Nominal 110,000 lbs.	14. Coupler centering device	None
2. Load limit	121,000 "	15. Coupler uncoupling device	Imperial "B"
3. Light Weight	48,000 "	AIR BRAKE	
4. Maximum load on rails	169,000 "	16. Brake schedule	W.A.B. "AB" 10" x 12"
BODY		17. Brake power	28,744 lbs. 60%
5. Framing - Underframe steel	Superstructure Steel	HAND BRAKE	
6. Floor 1/4" steel, Sheathing 1/4" steel St. Pockets None		18. Operating Device	Ajax 22" wheel
DOORS		TRUCKS	
7. Door operating device	Enterprise	19. Frame	Cast Steel
8. Door opening	4 - 13" x 24"	20. Dead Lever Fulcrum	Wine Brake Balancer
ROOF		21. Side Bearing	Stucki
9. Make Hatch Opening 2' x 3'	Hutchins Steel	22. Lateral motion device	Barber
10. Carlines - Make Hutchins Steel	Number 10	23. Snubber	Simplex Unit Type
DRAFT		24. Axles	A.A.R. 5 1/2" x 10"
11. Draft Gear	Miner A-22-XB	25. Wheels	Cast Iron A.A.R. 33"
12. Draft attachments	Farlow two-key	26. Brake beam auxiliary support	Single Economy - Creco
13. Couplers	A.A.R. Type "E"	27. Train length coupled	34' 9"

SAND CARS X-1213 FOR COMPANY SER. 1953