

Built June-July 1951 Greenville Steel Car. Co. Order No. 00.559

"DF" Damage Free Loaders applied October and November 1952

By Evans Products Company

Box Cars No. 29217, 29218, 29224, 29227
29242, 29243, 29294

Class XML

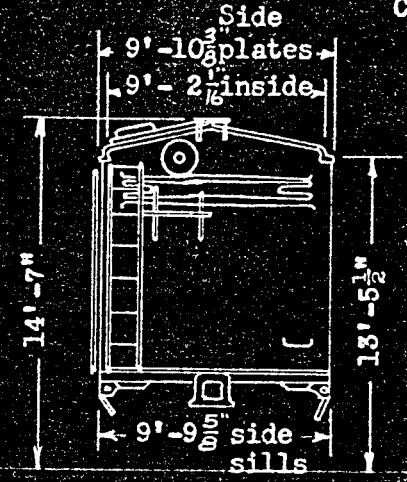
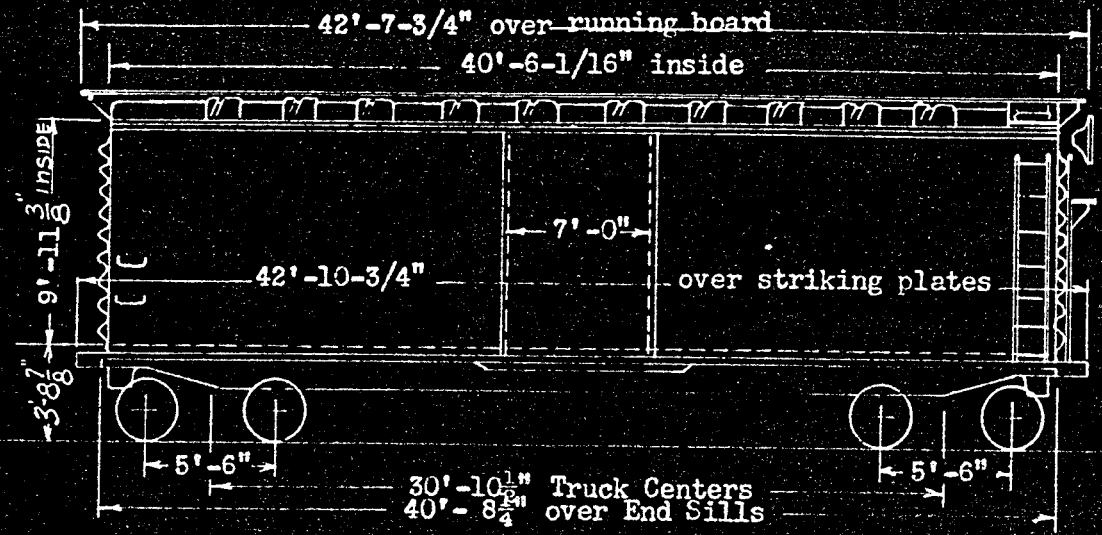

GENERAL		DRAFT (Continued)	
1. Capacity - Level	3695 cu.ft.	Nominal	100,000 lbs.
2. Load Limit			112,400 lbs.
3. Light Weight			56,600 lbs.
4. Maximum Load on Rails			169,000 lbs.
BODY		BRAKES	
5. Framing-Underframe	Duryea Cushion-Superstructure Steel	19. Brake Schedule	W.A.B.Co. "AB" 10" x 12"
6. Floor - 2-3/8" Y.P.	Sheathing .10 Steel	20. Brake Power	32,364 lbs. 60%
7. Doors	7'-0" x 9'-3-7/8" Youngstown	21. Hand Brake "Non-Spin"	Miner
8. Door fixtures	Roller Lift Improved Camel	TRUCKS	
9. Floor Protection Plates in doorway	-3/16" steel SREMcO	22. Frames	2 1/2" Spring Travel A-3 Ride Control A.S.F.
10. Loaders "DF" Damage Free	Evans	23. Slack Adjuster	Type "K" Royal
11. Roof	Diagonal Panel Solid Steel SREMcO	24. Brake Lever and Bottom Connectors	Schaefer
12. Ends	Improved Dreadnaught SREMcO	25. Side Bearings	Stackl
13. Side and End Ladders	"Safe Grip" Wine	26. Snubbers	Bolster Friction Block
DRAFT		27. Axles - AAR 5 1/2" x 10"	Wheels - 1-wear Wrot Steel 33"
14. Draft Gear	Single Spring Duryea	28. Brake Beam Hanger	Loop Type Flannery
15. Draft Key - AAR	Retainer Lock IRECo.	29. Brake Beam Support and Safety Device	Creco 4-Point
		30. Train Length Coupled	45' - 2-1/4"