

"DF" Damage Free Loaders applied October and November 1952

By Evans Products Company

Class XML

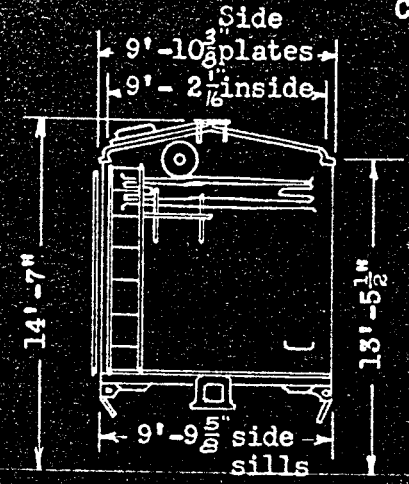
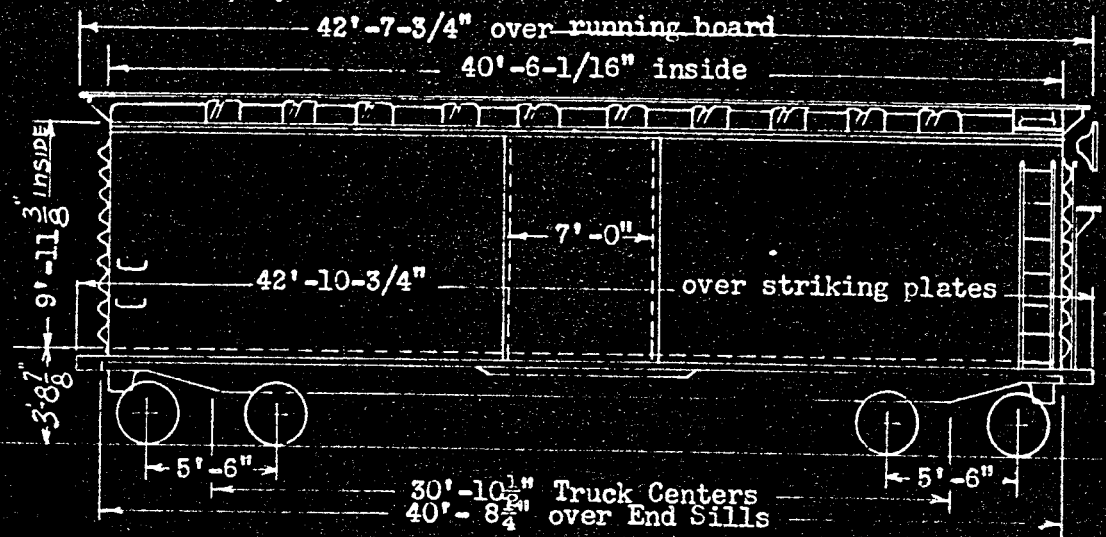

GENERAL		DRAFT (Continued)	
1. Capacity - Level 3695 cu.ft.	Nominal 100,000 lbs.	16. Coupler	AAR Type "E" 6-1/4" x 8" Bottom Operated
2. Load Limit	112,400 lbs.	17. Striker & Coupler Carrier with Coup.Ht.Adjust.	SREMCo.
3. Light Weight	56,600 lbs.	18. Coupler Uncoupling Device	Standard "Safety" SREMCo.
4. Maximum Load on Rails	169,000 lbs.	BRAKES	
BODY		19. Brake Schedule	W.A.B.Co. "AB" 10" x 12"
5. Framing-Underframe Duryea Cushion-Superstructure Steel		20. Brake Power	32,364 lbs. 60%
6. Floor - 2-3/8" Y.P.	Sheathing .10 Steel	21. Hand Brake "Non-Spin"	Miner
7. Doors	7'-0" x 9'-3-7/8" Youngstown	TRUCKS	
8. Door fixtures	Roller Lift Improved Camel	22. Frames	2 1/2" Spring Travel A-3 Ride Control A.S.F.
9. Floor Protection Plates in doorway	-3/16" steel SREMCo	23. Slack Adjuster	Type "K" Royal
10. Loaders "DF" Damage Free	Evans	24. Brake Lever and Bottom Connectors	Schaefer
11. Roof	Diagonal Panel Solid Steel SREMCo	25. Side Bearings	Stacki
12. Ends	Improved Dreadnaught SREMCo	26. Snubbers	Bolster Friction Block
13. Side and End Ladders	"Safe Grip" Wine	27. Axles - AAR 5 1/2" x 10"	Wheels - 1-wear Wrot Steel 33"
DRAFT		28. Brake Beam Hanger	Loop Type Flannery
14. Draft Gear	Single Spring Duryea	29. Brake Beam Support and Safety Device	Creco 4-Point
15. Draft Key - AAR	Retainer Lock IRECo.	30. Train Length Coupled	45'- 2-1/4"