

Built Se. 1953, ACF Order No. 01-3959
 Repaired Company Shop, Nov.-Dec. 1970
 REPAIRED COMPANY SHOPS OCT. 71 to FEB. 72 (25111-25155)

Box Cars, Nos. 25001-25
 Class XM

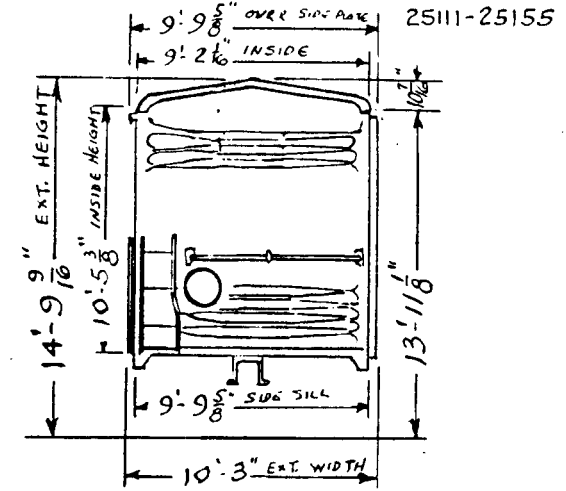
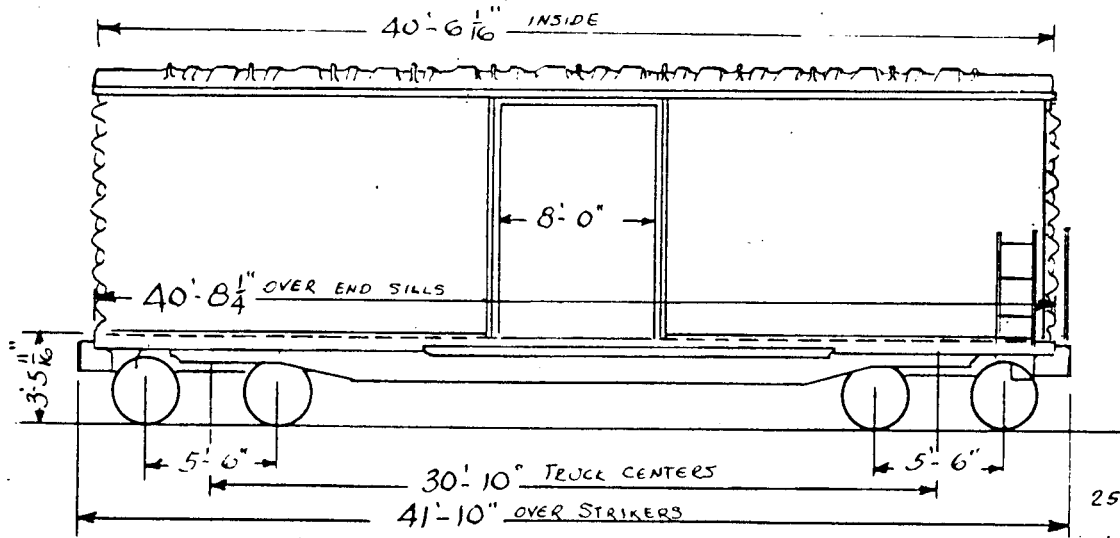

25111-25155 AUTOMATIC SLACK ADJUSTER - ELLCON-NATIONAL 2000W
 " " JOURNAL STOPS-LID SEALS - JOURNAL PADS - REAR SEALS - UNITY
 " " (10 CARS) SLIDEWELL DOOR CONTROL - HENNESSY

GENERAL		DRAFT (continued)	
1. Capacity - 3860 cu. ft.	Nominal 110,000 lbs.	16. Striker - Weldment	ACF
2. Load Limit	128,200 lbs.	17. Coupler Uncoupling Device "Standard"	SREMCo
3. Light Weight	48,800 lbs.	BRAKES	
4. Maximum load on Rail	177,000 lbs.	18. Brake Schedule WABCO	7 1/2" Cylinder Conversion Kit
BODY		19. Brake Power	10.6% Gross Rail Load
5. Underframe and Body	Welded construction	20. Hand Brake Equipco, Universal; Brake shoes Comp. H4A	
6. Floor 2 1/4" laminated hardwood; Floor Stringers 3 ea. side		TRUCK	
7. Doors 8'-0" x 9' 10-1/8"	Youngstown	21. Frames	2 1/2" spring travel
8. Door Fixtures	Roller Lift Improved Camel	22. Brake Beams Creco Positive No. 18; Brake shoes Comp. H4A	
9. Side Sill Reinforcement	15" 40# Channel	23. Slack Adjuster Universal 1900 auto.; Journal Steps Hennessy	
10. Roof	Diagonal Panel Steel SREMCo	24. Brake Lever and Bottom Connectors	Schaefer
11. Ends	Improved Dreadnaught SREMCo	25. Side Bearings Stucki; Bnabbers Bolster Friction Block	
12. Side and End Ladders	A.C.F.	26. Axles AAR 5 1/2"x10";	Wheels 1-Wear Wrot Steel 33"
DRAFT		27. Journal Box Lids	Edgewater Sealing Type
13. Draft Gear Miner, Cardwell-Westinghouse, Hulson 202-A		28. Journal Lube Pads Oilwell; Rear Seals AR-18A Guardwell	
14. Draft Key A.A.R.	Retainer Lock A.A.R.	29. Brake Beam Hangers Flannery; Sup.&Safety Dev.Creco 4 Pt	
15. Coupler AAR Type "E" 6 1/4"x8"	Bottom Operated	30. Train Length Coupled	44' 4"