

41c

Bethlehem Booster - Maximum
Tractive Power 15840 lbs.
Cyclone Spark Arrester

Engine No. 842
Class H9-a

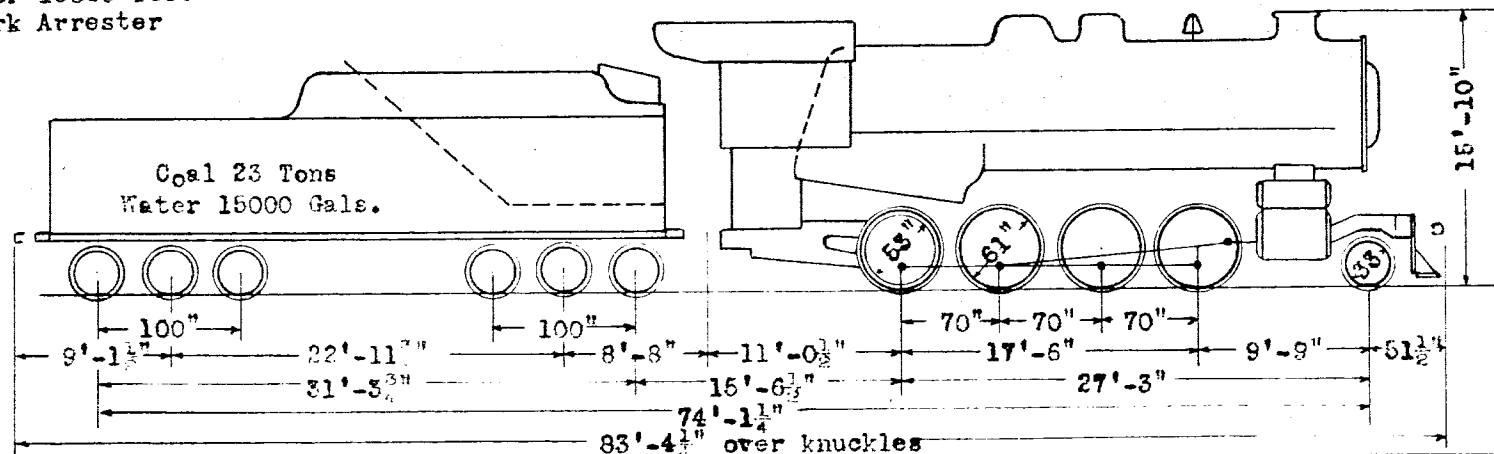

GENL. DATA

1. Cylinders, dia. x stroke	27" x 32"	29. Heating surface, tubes & flues	sq.ft. 3156
2. Valve gear	Walschaert	30. " " firebox, arch tubes & syphons	" 317
3. Valves, size & kind	14" Piston	31. " " total	" " 3473
4. " maximum travel	7"	32. " " superheater	" " 945
5. " steam lap	1-1/8"	33. " " equivalent total	" " 4890
6. " exhaust clearance	Line	34. Grates, length x width	112" x 96 1/2"
7. " lead in full gear	3/16"	35. " area	sq.ft. 74.9
8. " cut off in full gear	88.3%	36. Brick arch, type	Security
9. Rated tractive power	71,500 lbs.	37. Arch tubes O.D., Ga., Fin. Lgth. over Bd. 3 1/2" - 7-B.W.G. - 119"	
10. Ratio of Adhesion (Wt. on Drivers ÷ Trac. Power)	4.02	38. Stoker, type	Duplex D2
11. Sharpest curve	22 Deg.	AIR BRAKE	
WEIGHT	Light	39. Schedule	W.A.B. 6-ET, WN4, 1612, Type 47B
12. Leading truck	22,000	40. Brake Power	46% 134,000 lbs.
13. Driver, first	73,900	41. Pumps	2 - 8 1/2" CC
14. " second	73,300	AXLES	
15. " third	72,000	42. Leading truck	Journal Dia. x Lgth. 6" x 12"
16. " fourth	68,710	43. Driving, main	" " " 12" x 13"
17. " total	287,910	44. " other than main	" " " 11" x 13"
18. Trailing truck	None	45. Trailing truck	" " " None
19. Total engine	254,500	TENDER	
20. Tender, front truck	142,800	46. Frame	Commonwealth cast steel
21. " back	142,800	47. Draft gear	Farlow-Miner A-18-S
22. " total	114,600	48. Brake schedule	W.A.B. 6-ET 1812 Type "Q"
23. Total engine & tender	369,100	49. Brake power	118% 135,000 lbs.
BOILER		50. Truck type	Commonwealth 6-wheel
24. Working pressure, maximum	220 lbs.	51. Axles	A.R.A. 6" x 11"
25. Firebox, length x width	112" x 96 1/2"	52. Wheels	Steel 33"
26. Tubes, No., O.D., & Gauge	231-2 1/2" - 11-B.W.G.	53. Maximum width over cylinders	11' 1"
27. Flues, No., O.D., & Gauge	50-5 1/2" - 9-B.W.G.	54. " " " running boards, at cab	11' 0"
28. Tubes & Flues, length (in to in of tube sheets)	182"		