

TENDERS		CLASS A-1-a-A-1
CLASS	ENG NO	
W-5-B	1267	
W-6-B	1284	

ALL DIMENSIONS ARE GIVEN WITH ENGINE AND TENDER IN WORKING ORDER, AND WITH NEW WHEELS AND TIRES

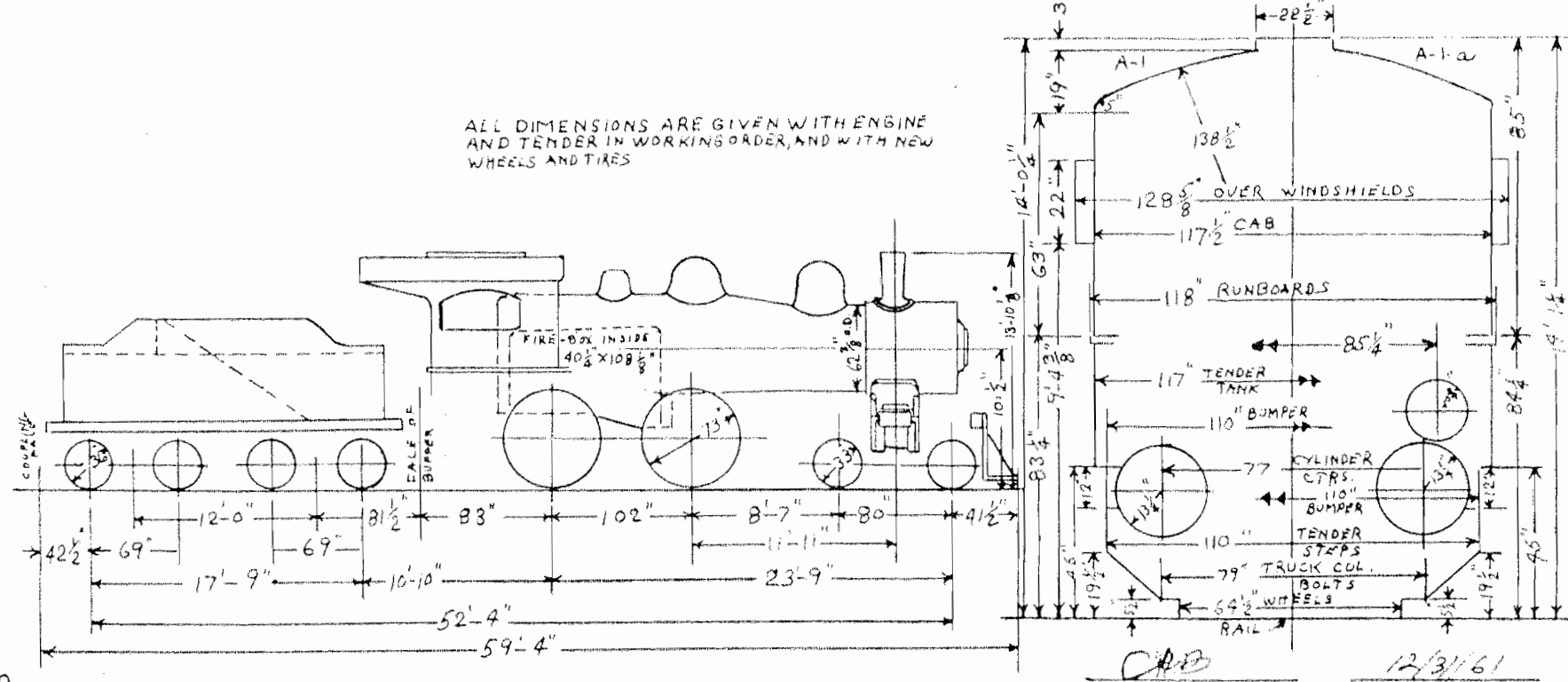

B22

CAB 12/31/61

BOILER DATA

TENDER DATA

GENERAL DATA

ITEM	B.W.G.	DIAM	HEATING SURFACE SQ. FT.				TENDER DIMS IN INCHES	LOADED WT. LBS.	CAPACITY WATER COAL	TENDER CLASS	BOILER PRESSURE 200 LBS			
			32 FLUES 1 1/2" DIA	163 FLUES 1 1/2" DIA	159 FLUES 1 1/2" DIA	N 5/8" LONG					TRACTIVE EFFORT	MAX. CURVATURE		
SMALL FLUES	158	1/2 MIN	2"	1947	963	940	934	8012	98000	4600	8	W-2-a	22556 LBS.	17°
LARGE FLUES	24	1/2 MIN	5 1/2"		393	393	393	8009	110800	5500	10	W-4-a		
TOTAL FLUES				1947	1356	1333	1327	8010	110800	5500	10	W-4-c	WT. ON DRIVERS	86000*
FIRE BOX PROPER				167	167	167	166	8010	116000	6000	10	W-5-b	WT. ON ENG. TRUCK	43000*
SYPHONS	(1)						24	8008	138300	7000	12	W-6-b	TOTAL ENG. WT.	131000*
ARCH TUBES	2	1/8 MIN	3"	15	15	15		8008	133300	7000	12	W-6-c	FACTOR OF ADHESION	385
TOTAL FIRE BOX				182	182	182	193	8018	138300	7000	12	W-6-c	VALVE GEAR	STEVENSON SOUTHERN
PRIMARY HTG SURFACE				2129	1538	1515	1522	8009	120000	6000	10	W-5-a	CYLINDERS	20" X 24"
SUPER HTG SURFACE					309	309	309	8008	120000	6000	10	W-5-b	VALVE	D T Y PE
GRATE AREA						38.2	59.4		133000	6000	10	W-6-c		