

WHERE USED
 DIESEL WRECKING
 DERRICK
 D-3

CONVERTED FROM STEAM DERRICK AT READVILLE SHOPS SEPT. 1955.
 ENGINE:- CATERPILLAR MODEL D337 DIESEL ENGINE
 SPEED- IDLE, 550 R.P.M. ; FULL, 1600 R.P.M.
 TORQUE CONVERTER:- TWIN DISC MODEL CRR-10032-1
 DRIVE:- LINK-BELT SILENT CHAIN
 AIR COMPRESSOR:- W.A.B. CO. 4YC- 220 R.P.M. AT IDLE SPEED,
 640 R.P.M. AT FULL SPEED
 GENERATOR :- CATERPILLAR 32 VOLT, 50 AMP, CAPACITY
 BATTERY :- EXIDE KT-23 16 CELLS
 FUEL CAPACITY:- 140 GAL.

BACK-UP LAMPS - 2 REQ'D.
 PYLE-NAT. COS. CAT. NO. TSL-1095-W

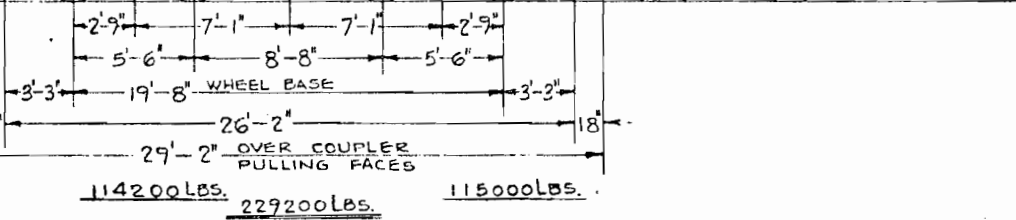
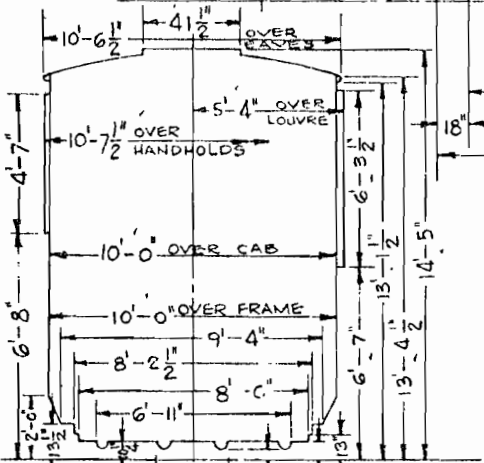
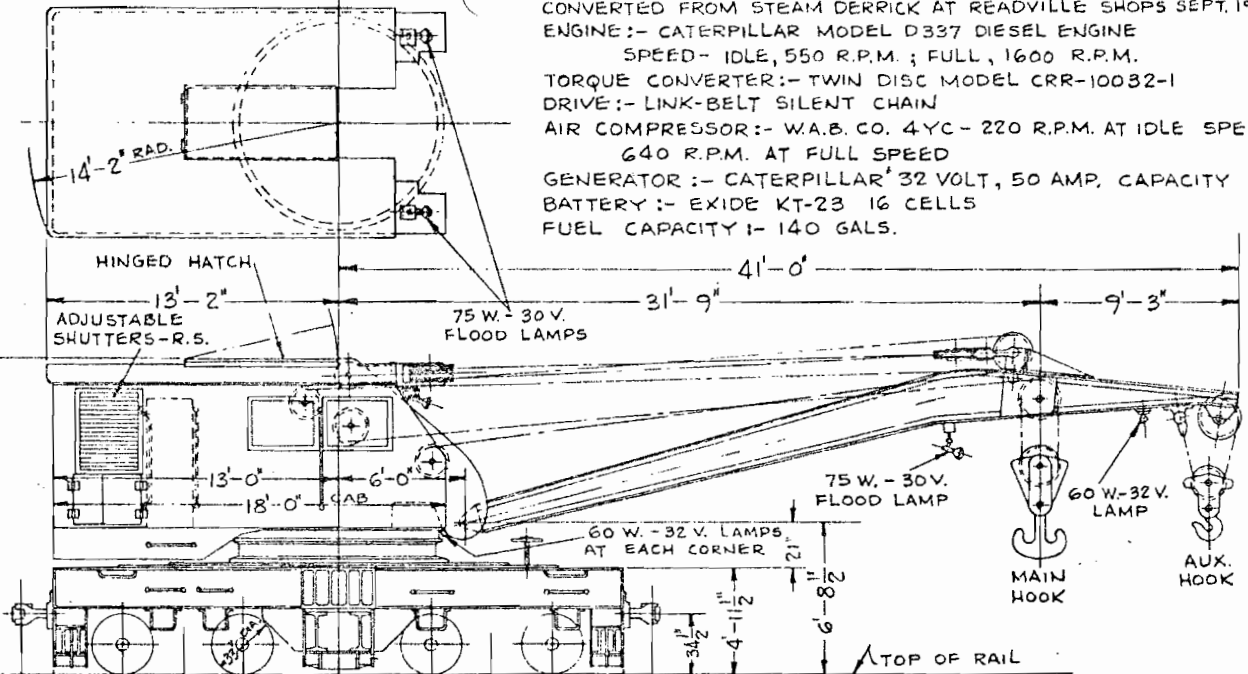
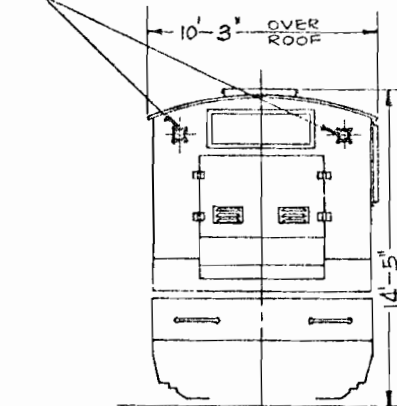

CAPACITIES WITH ALL JACK BEAMS IN POSITION
 MAIN HOIST - 7 PART BLOCK
 300000 LBS. AT 17 FT. RADIUS
 200000 LBS. AT 21 FT. RADIUS
 150000 LBS. AT 25 FT. RADIUS
 100000 LBS. AT 30 FT. RADIUS
 AUX. HOIST - 2 PART BLOCK
 60000 LBS. AT 23 TO 37 FT. RAD

N.Y., N.H. & H.R.R.
 NEW HAVEN AUG. 29, 1955.
 DIESEL WRECKING DERRICK
 150 TON CAPACITY
 CORRECT APPROVED
 ASST. M.E. 25917 *H. F. Hackett*
 M.E.

DR	TR	CK	IN
ESS	K		

CLEARANCE DIAGRAM

IN	CK	BY	WHY	REISSUED	DATE	LETTER