

WHERE USED
 58
 50 TON GONDOLA CARS
 60500-60649
 60500-60649

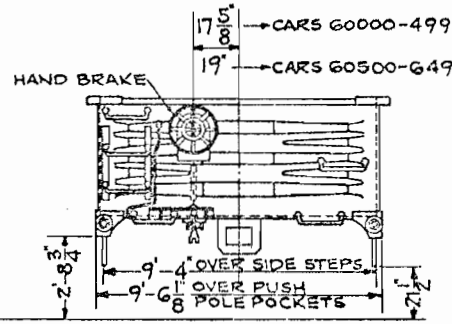
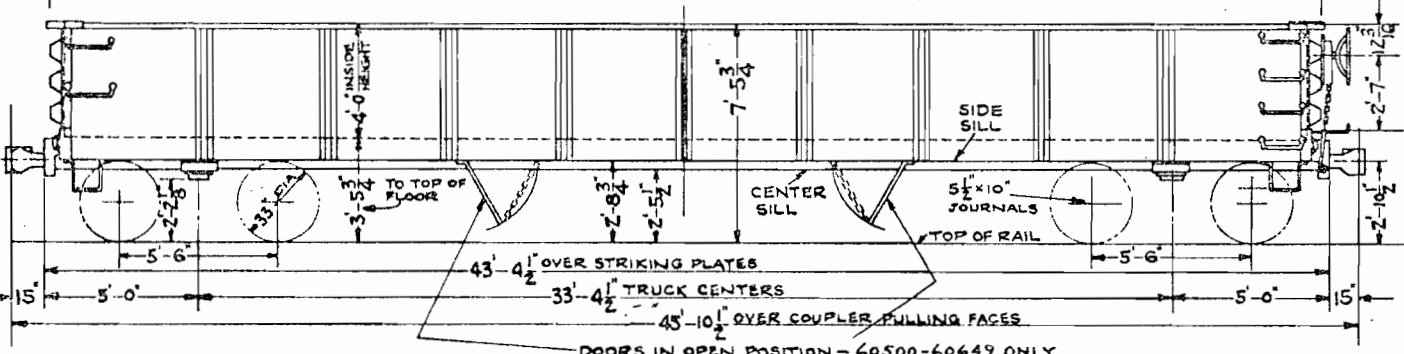
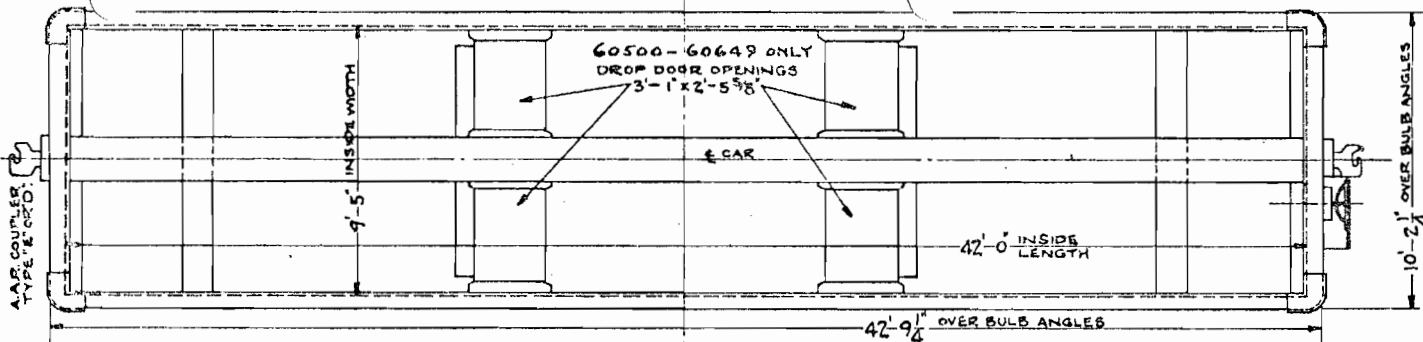

DOORS IN OPEN POSITION - 60500-60649 ONLY
 DESCRIPTIVE DATA

CARS 60000-60499

ALL STEEL CAR-BUILT AT NEW HAVEN-1930.
 LIGHT WEIGHT OF CAR-41000 LBS.
 CUBIC FEET CAPACITY-1572 (LEVEL FULL).
 AIR BRAKE-WESTINGHOUSE "AB" WITH 10" X 12" CYLINDER.
 DRAFT GEAR-MINER "A-79-X".
 COUPLER-AAR TYPE "D", 6" X 8" KEY TYPE SHANK, WITH CAST STEEL YOKE AND U.M.P. CO'S CENTERING DEVICE.
~~COUPLER-MINER "A-79-XB" WITH "SERVEX" CARRIER.~~
 TRUCKS-5 1/2" X 10" AAR TYPE CAST STEEL SIDE FRAME.
 HAND BRAKE:- MINER, KLASING OR UNIVERSAL.
 "KASS" SAFETY TREAD BRAKE STEP.
 CAR IS EQUIPPED WITH DREADNAUGHT STEEL ENDS.

CARS 60500-60649.

ALL STEEL CAR-BUILT AT READVILLE-1937.
 LIGHT WEIGHT OF CAR-41000 LBS.
 CUBIC FEET CAPACITY-1572 (LEVEL FULL).
 AIR BRAKE-WESTINGHOUSE "A-B" WITH 10" X 12" CYL.
 DRAFT GEAR-MINER "A-79-XB" WITH "SERVEX" CARRIER.
 COUPLER-CAST STEEL AAR TYPE "E", 6 1/4" X 8" KEY TYPE SHANK WITH U.M.P. CO'S CENTERING DEVICE AND CAST STEEL YOKE.
 DOOR MECHANISM:- STD. STEEL CAR CO'S RATCHET TYPE.
 TRUCKS-DALMAN ONE LEVEL INTEGRAL BOX CAST STEEL SIDE FRAME WITH 5 1/2" X 10" AAR. STD. JOURNALS.
 HANDBRAKE:- AJAX
 "KASS" SAFETY TREAD BRAKE STEP.
 CAR IS EQUIPPED WITH DREADNAUGHT STEEL ENDS.

THIS DWG. SUPERSEDES SK. NO. 8053.

N. Y., N. H. & H. R. R.
 NEW HAVEN MAY 17, 1939.

DIAGRAM
 50 TON GONDOLA CARS
 60000-60649

CORRECT

APPROVED

B. Jones
 ASST. M. E.

24125

[Signature]
 M. E.

IN.	CK.	BY	WHY REISSUED	DATE	LETTER
K	TR		TYPE OF HANDBRAKE CHANGED ON 60000-499 SERIES-WAS AJAX	3-27-48	C
W	R/C		DROP DOORS REMOVED FROM 60000-60499 "AB" BRAKE APPLIED ALL CARS	10-4-47	B
G	ESS		RETRACTED CARS 60000-60499 & ADDITIONAL INFORMATION ADDED.	7-17-39	A

DR. TR. CK. IN.
 RS. ESS. G.